

# OWNER'S MANUAL



**HOT ROD/HOT SPOTTER**  
026-2                      026-1\*



*You have just purchased one of the finest and most desirable devices for automotive and boat detailing.*

*Read the following information to obtain maximum performance and to acquaint yourself with your new Aztec Products Hot Rod/Hot Spotter features.*

*\*As shown, Hot Spotter 026-1*

## **BEFORE YOU START:**

- SAFETY
- OPERATION
- PARTS
- TROUBLESHOOTING
- RETURN GOODS POLICY
- WARRANTY



**READ and UNDERSTAND this material before operating or servicing this equipment. Failure to understand how to safely operate this tool could result in an accident causing injury or death.**

**INTRODUCTION**

This manual is designed to make your job easier. However, there is nothing more important than the safety aids and instructions that are found throughout this document. The Safety Alert Symbol is used to identify topics of primary safety concern wherever they appear. Further, a separate section has been included, "Important Safety Instructions," which deals mainly with accident prevention concepts.

User experience provides the best feedback. We, at Aztec Products, Inc., welcome your comments and suggestions.

**Purpose of this Manual**

This instruction manual is intended to familiarize operators with safety and maintenance procedures of Aztec Products, Inc. products.

This manual should be kept available to all operating and maintenance personnel.



**SAFETY ALERT SYMBOL**

The symbol above is used to call your attention to instructions concerning your personal safety. Watch for this symbol. It points out important safety precautions. It means "**ATTENTION! Become alert! Your personal safety is involved!**" Read the messages that follow and be alert to the possibility of personal injury or death.



**DANGER**

Immediate hazards which, if not avoided, WILL result in severe personal injury or death.



**WARNING**

Hazards or unsafe practices which, if not avoided, COULD result in severe personal injury or death.



**CAUTION**

Hazards or unsafe practices which, if not avoided, COULD result in minor personal injury or property damage.

Safety is a critical factor in the design of Aztec Products, Inc. equipment. The best program starts with a safety conscious operator. The information highlighted in this manual describes operating practices for the benefit of the workers who will use our equipment in their daily jobs. Comments from users are appreciated.

**SPECIFICATIONS**

	<b>HOT ROD</b>	<b>HOT SPOTTER</b>
Hose Length	16 ft	10 ft
14 Gauge Power Cord Length	50 ft.	15 ft.
Tool	Stainless Steel	PVC
Heated Solution Tank	190°F	190°F
Solution Tank Capacity	1.5 Gallons	1.5 Gallons
Recovery Tank Capacity	2 Gallons	2 Gallons
Vacuum Lift	102 Inches	102 Inches
Piston Pump	60 PSI	60 PSI
Heating Element	1400 Watt	1400 Watt
Power Requirement	Less than 15 Amps	Less than 15 Amps
Circuit Breaker	20 Amp	20 Amp
Vacuum Hose	1 1/4" ID	1 1/4" ID
Solution Hose	3/16" ID	3/16" ID
Machine Weight	33 pounds*	18 pounds
Dimensions	H-18" L-18" W-13"	H-18" L-18" W-13"

\*Additional weight due to longer hose and power cord

Both units have an Integrated Float/Temperature Gauge and maneuver easily on 2 inch casters. Applications include auto and boat detailing, commercial and household carpet and upholstery cleaning.

**IMPORTANT SAFETY INSTRUCTIONS**

Anyone designated to operate this equipment must, without fail, read and understand these instructions before attempting to operate the equipment.

**WARNING**

To reduce the risk of fire, electric shock, or injury:

- Always use a grounded electrical outlet.
- Turn off all controls before unplugging.
- Always disconnect electrical cable from outlet before attempting adjustments or repairs.
- Do not leave the appliance when it is plugged in. Unplug the unit from the outlet when not in use and before servicing.
- Do not unplug by pulling on the cord. To unplug, grasp the plug, not the cord.
- Do not operate if power cords, hoses, etc. are cracked, frayed, leaking or otherwise in need of repairs. Replace the entire cord when the cord or plug is damaged in any way.
- Do not handle the plug, cord or appliance with wet hands.
- Do not operate in standing water.
- To avoid electric shock, do not expose to rain. Store indoors.
- Do not allow the unit to freeze.
- Do not pull or carry by the cord, use the cord as a handle, close a door on the cord or pull the cord around sharp edges or corners.

- Do not run the appliance over the cord. Keep the cord away from heated surfaces.
- Do not put any object into openings. Do not use with any opening blocked; keep free of dust, lint, hair, and anything that may reduce air flow.
- Keep loose clothing, hair, fingers, and all parts of body away from openings and moving parts.
- Do not operate under any unsafe conditions.
- Do not use to pick up flammable or combustible liquids such as gasoline or use in areas where they may be present.
- Never put flammable or explosive materials in this equipment. Never operate equipment in an environment where these materials are present.
- Use extra care when cleaning on stairs.
- Do not allow to be used as a toy. Close attention is necessary when used near children.
- Use only as described in this manual. Use only the manufacturer's recommended attachments.

**INTENDED USE**

The Heated Carpet Spotter is intended for commercial use, cleaning and extracting floors, furniture, draperies and automobile interiors in an indoor environment. This machine is intended for wet pickup only. We do not recommend using these machines for any other purpose.

**WARNING**

Disconnect power before working  
Electric shock may occur

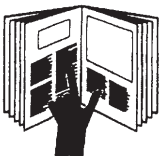
**WARNING**

A person who has not read and does not understand all operating instructions is not qualified to operate this tool.

Failure to read and understand safety instructions may result in injury or death.

**SAVE THESE  
INSTRUCTIONS!**

### GROUNDING INSTRUCTIONS

This appliance must be grounded. If it should electrically malfunction, grounding provides a path of least resistance for electric current to reduce the risk of electric shock. This appliance is equipped with a cord having an equipment grounding conductor and grounding plug. The plug must be plugged into an appropriate outlet that is properly installed and grounded in accordance with all local codes and ordinances.

## DANGER

Improper connection of an equipment grounding conductor can result in risk of electric shock. Check with a qualified electrician or service person if you are in doubt as to whether the outlet is properly grounded. Do not modify the plug provided with the appliance. If it will not fit the outlet, have a proper outlet installed by a qualified electrician. This appliance is for use on a nominal 120 volt circuit, and has a grounding plug that looks like the plug illustrated in Figure 1. A temporary adapter illustrated in Figures 2 and 3 may be used to connect this plug to a two pole receptacle, as shown in Figure 2 if a properly grounded outlet is not available. The temporary adapter should be used only until a properly grounded outlet (Figure 1) can be installed by a qualified electrician. The green colored rigid ear, tab, or the like extending from the adapter must be connected to a permanent ground such as a properly grounded outlet box cover. Whenever the adapter is used, it must be held in place by a metal screw. Grounding adapters are not approved for use in Canada. Replace the plug if the

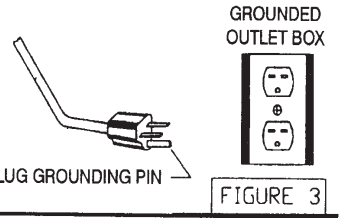
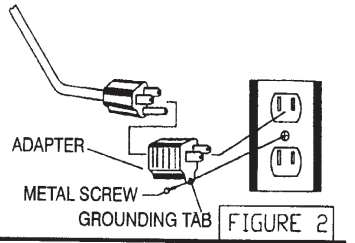
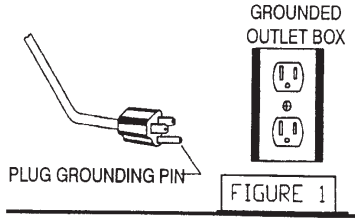

grounding pin is damaged or broken. The Green (or Green/Yellow) wire in the cord is the grounding wire. When replacing a plug, this wire must be attached to the grounding pin only. Extension cords connected to this machine should be 12 gauge, three wire cords with three prong plugs and outlets. DO NOT use extension cords more than 50 feet (15 m) long.

## RETURN GOODS POLICY

As our customer, you are aware that the design and construction of this product are both innovative and unique. Since this is true, in order to troubleshoot our equipment, we rely heavily on returned defective or failed parts so that we can examine the causes of failure. While this may at first seem to be an inconvenience, ultimately you benefit from safer, better designed machine components. Please give us the opportunity to serve you better by following these RGA (Return Goods Authorization) rules.

1. We maintain the serial number, date of shipment or sale, and customer name on each piece of equipment sold. If you were the purchaser, please reference that information on your request for replacement or repair. If you purchased the equipment through a dealer, please include the company name, the date, and the serial number of the product.
2. Ask for an RGA number when you are ordering the replacement part. Return the failed part within 14 days, freight prepaid, exactly as it was at the time of failure. Our inspection and evaluation will attempt to determine the probable cause of failure.

3. If our inspection reveals that the failed part was defective, we will credit your account for the entire amount of the part including your cost of return freight, but not packaging expense. When incomplete parts are returned for credit, their condition or state of incompleteness will be assessed against the credit claim.
4. We will not accept freight collect returns or returns that do not indicate the RGA # on the packing list.

Your satisfaction is extremely important to us. We intend to be reasonable on any matter that is related to our warranty service or other wear-related problems which our customers feel need attention. Please help us to help you. Before assuming that a part is defective, check the repair manual to see if the problem might be something that you or one of your employees might be capable of correcting. If it is not, follow the above policy and depend on us to respond quickly and responsibly.

## PREPARING FOR USE AND OPERATING THE MACHINE

### SPOTTING PROCEDURES PRIOR TO OPERATING MACHINE

- 1 Soak up excess liquids with a towel.
- 2 Test cleaner on a small inconspicuous area to make sure it will not damage the carpet fibers.
- 3 Apply appropriate spotter, following directions on bottle.
- 4 Start at outside edges of stain and work toward the center. Use a dabbing, not a rubbing action.
- 5 Repeat steps 3-4 if needed.

### OPERATING THE MACHINE



#### WARNING

***This machine is intended for hot water use only. Chemicals may be applied directly to the surface being cleaned. Use only nonflammable commercial chemicals intended for carpet application.***

- 1 UNPLUG machine before attempting to fill with water.
- 2 Pour up to 1 1/2 gallons of the warmest water possible (to shorten heating time) into the front solution tank. Tank must be at least half full before heating cycle will begin.
- 3 Toggle the power switch to "HEAT". The amber light will come on indicating the heating cycle has begun.
- 4 When water temperature reaches maximum heat, the amber light will go out and the machine is ready for use.
- 5 Toggle the power switch to "VACUUM".
- 6 Release water from nozzle until hot water transfers through the length of the vacuum hose.



#### CAUTION

***Do not continue to use the machine after the Recovery Tank is FULL. This will damage the vacuum motor and is NOT COVERED UNDER WARRANTY.***



#### DANGER

***HOT WATER! BE AWARE!  
WATER TEMPERATURE  
MAY EXCEED 200°F.  
USE CAUTION WHEN USING  
THIS MACHINE.***



#### WARNING

***To reduce the risk of electric shock or injury, unplug the power cord before servicing.***

### AFTER USE MAINTENANCE

At the completion of **every use** you must perform these simple procedures to ensure proper machine operation and cleaning performance.

- Turn Power Switch to the "OFF" position to turn both the vacuum motor and the solution pump OFF.
- DISCONNECT THE POWER CORD.
- Disconnect the Hose Assembly from the machine.
- Tip the Recovery Tank and drain through hose connection port.
- Tip the Solution Tank and drain unused water or solution. Rinse the tank thoroughly of any debris or cleaning chemical residue.
- Unscrew the tank covers and set aside to allow for air-drying and prevention of odor buildup.
- Remove the spray tips (1/4 turn) from the upholstery tool and put them in a glass or plastic container with a solution of 25% vinegar and water overnight to remove any residue.

**Note:** To flush out or clean the solution tank and hose, make a one-gallon solution of 25% vinegar and warm water, and pour it into the solution tank. Turn on the switch, spray until all of the solution has run through the pump and hose to remove any chemical residue. Failure to flush the solution system will result in poor spray patterns and corroded jet spray tips.

TANK ASSEMBLY TOP VIEW

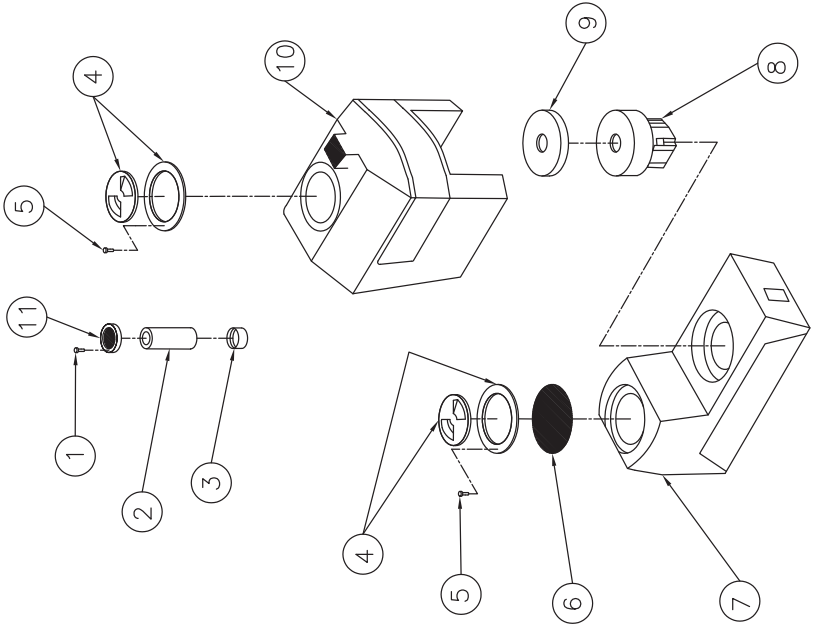

TANK PARTS LIST

PART #	DESCRIPTION	PART #	QTY
1	SCREW	S2-67	2
2	STACK TUBE	S2-02R	1
3	STACK ADAPTER	S2-03R	1
4	4" LID	S2-04	1
5	LID SCREW	S2-07	4
6	MESH GUARD	S2-33	1
7	SOLUTION TANK	S2-01ST-SW	1
		S2-01ST-DD	1
		S2-01ST-BL	1
		S2-01ST	1
		S2-19	1
8	VACUUM MOTOR	S2-20	1
9	VACUUM MOTOR GASKET	S2-01R-SW	1
10	RECOVERY TANK	S2-01R-DD	1
		S2-01R-BL	1
		S2-01R	1
11	STACK FILTER	S2-62	1

TANK ASSEMBLY BOTTOM VIEW

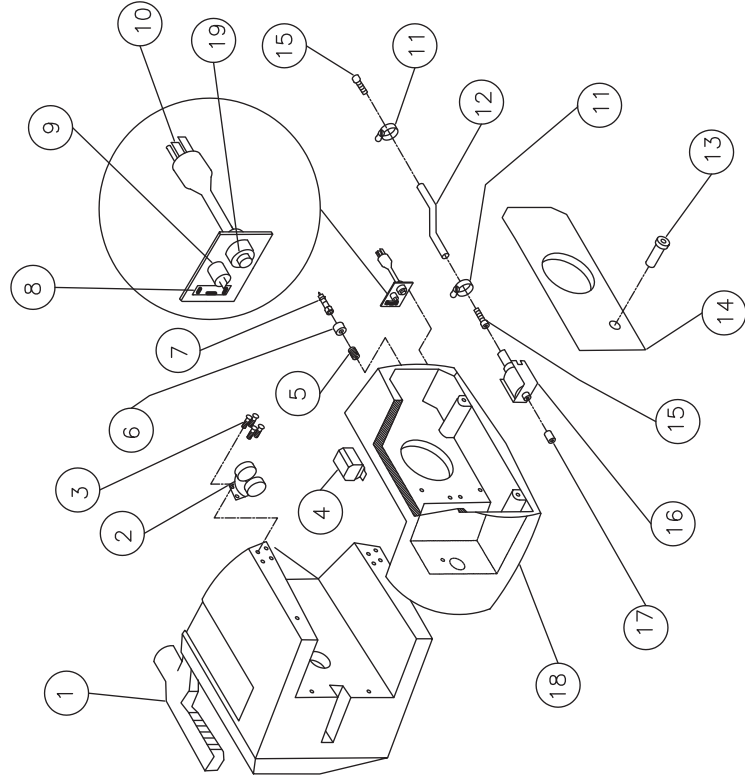

TANK PARTS LIST

PART #	DESCRIPTION	PART #	QTY
1	RECOVERY TANK	S2-01R-SW	1
		S2-01R-DD	1
		S2-01R-BL	1
		S2-01R	1
2	SWIVEL CASTER	S2-10	3
3	SCREW	S2-28	12
4	RELAY	S2H-36	1
5	BRASS NIPPLE	S2-13	1
6	NYLON SPACER	S2-14	1
7	QUICK COUPLING	S2-12	1
8	TOGGLE SWITCH	S2H-35	1
9	AMBER LIGHT	S2H-33	1
10	CORD	S2-86	1
		S2-88-12	1
		S2-26	1
11	HOSE CLAMP	S2-25	1
12	HOSE	S2H-17-20	1
13	CIRCUIT BREAKER	S2-27	1
14	BOTTOM COVER	S2-24	1
15	HOSE BARB	S2-23	1
16	PUMP	S2-75	1
17	NIPPLE	S2-01ST-SW	1
18	SOLUTION TANK	S2-01ST-DD	1
		S2-01ST-BL	1
		S2-01ST	1
19	STRAIN RELIEF FOR 15 FT CORD FOR 50 FOR CORD	S2-37	1
		S2-37A	1

## SOLUTION TANK ASSEMBLY AFTER SERIAL #2534

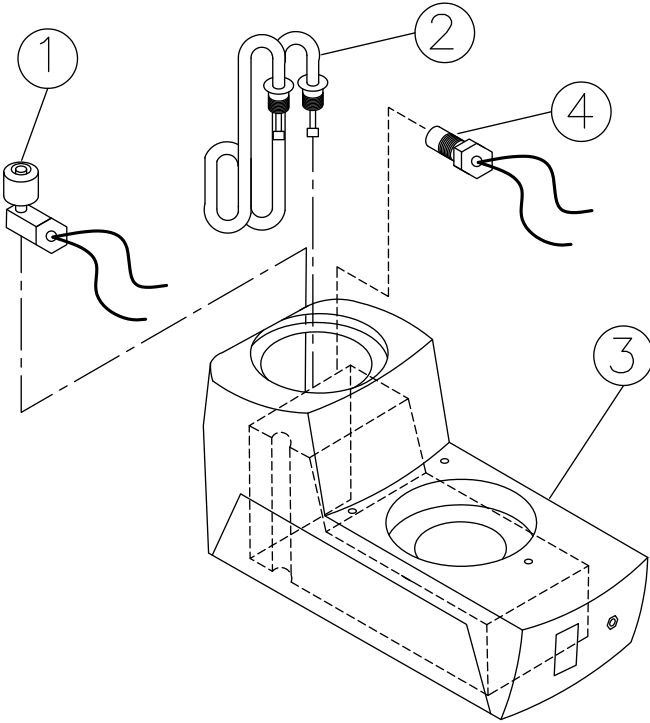

### SOLUTION TANK PARTS LIST

PART #	DESCRIPTION	PART #	QTY
1	FLOAT SWITCH	S2-21-90	1
2	HEATING ELEMENT	S2H-15-2006	1
3	SOLUTION TANK		
	BLUE	S2-01ST-SW	1
	RED	S2-01ST-DD	1
	BLACK	S2-01ST-BL	1
	GRAY	S2-01ST	1
4	TEMPERATURE PROBE	S2H-20	

## RECOVERY HOSE ASSEMBLY

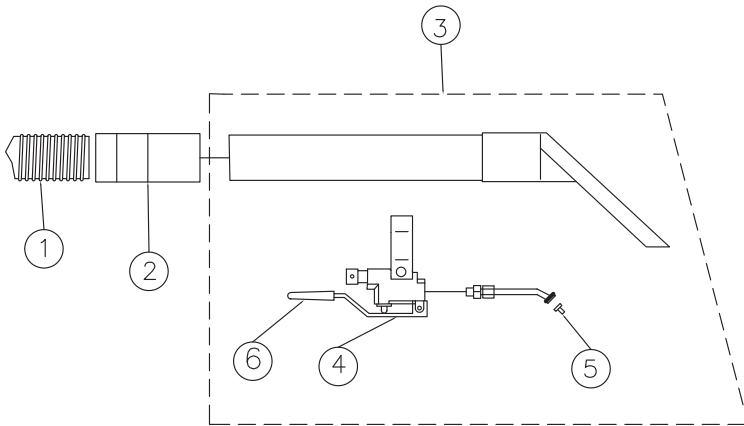
**PARTS LIST FOR RECOVERY HOSE ASSEMBLY**

<b>PART #</b>	<b>DESCRIPTION</b>	<b>PART #</b>	<b>QTY</b>
1	FLEX VACUUM HOSE	S2-47	1
2	HOSE CUFF	S2-47-CUFF	1
3	SPOTTING TOOL (CLEAR)	S2-38	1
	DETAILING TOOL (S STEEL)	S2-38-CD	1
4	ALUMINUM SPRAY VALVE	S2-85	1
5	SPRAY JET	S2-89	1
6	LEVER COVER	S2-44	1



**TROUBLESHOOTING**

<b>PROBLEM</b>	<b>POSSIBLE CAUSE</b>	<b>REMEDY</b>
<i>Will not heat (but vacuum comes on).</i>	<i>Water level too low.</i>	<i>Fill water to top edge of lid ring.</i>
<i>No solution from spray nozzle tip.</i>	<i>Nozzle tip clogged. Check quick-disconnect fitting. Solution tank empty. Pump failed. Kinked solution hose.</i>	<i>Disassemble and clean. Reconnect fitting onto machine. Refill water to top edge of lid ring. Replacement required. Straighten hose.</i>
<i>Poor water pickup.</i>	<i>Vacuum hose cuff is not firmly pushed onto recovery tank fitting. Vacuum motor intake filter is clogged. Vacuum gasket between tanks is worn or damaged. Recovery tank lid not sealing. <b>DEFECTIVE MACHINE! DO NOT ATTEMPT TO REPAIR!</b> Left exposed in freezing conditions. Defective pump seal.</i>	<i>Push hose cuff onto fitting. Check for cracks in hose. Remove and clean filter. Replace gasket. Replace or tighten lid. Unplug immediately and call factory Service Center or the point of purchase. Refer to Service Center. Replace pump.</i>
<i>Overheats and boils water.</i>	<i>Float level switch in solution tank may be damaged. Thermostat failure.</i>	<i>Replace float switch. Replace thermostat.</i>
<i>Plugged into outlet, nothing comes on. circuit.</i>	<i>Overloaded circuit breaker.</i>	<i>Circuit breaker reset. Unplug other electrical items on same</i>

**COMMON STAINS AND TREATMENT METHODS**

<b>STAIN TYPE</b>	<b>TREATMENT MATERIAL</b>	<b>STAIN TYPE</b>	<b>TREATMENT MATERIAL</b>
<i>Asphalt .....</i>	<i>Volatile solvent, Detergent</i>	<i>Egg (raw) .....</i>	<i>Liquid detergent</i>
<i>Beer .....</i>	<i>Liquid detergent, White vinegar</i>	<i>Food dye.....</i>	<i>Liquid detergent, Water</i>
<i>Berry stain.....</i>	<i>Liquid detergent, Ammonia 3-6%, Water</i>	<i>Furniture dye polish .....</i>	<i>Paint/Oil/Grease remover, Detergent</i>
<i>Bleach.....</i>	<i>Liquid detergent, Water</i>	<i>Gravy.....</i>	<i>Liquid detergent</i>
<i>Blood (dried) .....</i>	<i>Warm detergent, Ammonia 3-6%, Water</i>	<i>Lipstick.....</i>	<i>Paint/Oil/Grease remover</i>
<i>Blood (wet).....</i>	<i>Liquid detergent, Water</i>	<i>Mascara.....</i>	<i>Paint remover, Volatile solvent, Detergent, Water</i>
<i>Butter .....</i>	<i>Volatile solvent</i>	<i>Milk .....</i>	<i>Liquid detergent</i>
<i>Catsup or mustard .....</i>	<i>Liquid detergent</i>	<i>Orange drink.....</i>	<i>Liquid detergent, Water</i>
<i>Chewing gum .....</i>	<i>Volatile solvent</i>	<i>Shoe polish .....</i>	<i>Heated iron into clean towel, Volatile solvent</i>
<i>Chocolate .....</i>	<i>Liquid detergent, Ammonia, Water</i>	<i>Tea.....</i>	<i>Liquid detergent</i>
<i>Coffee.....</i>	<i>Detergent, White vinegar, Volatile solvent</i>	<i>Tomato juice.....</i>	<i>Liquid detergent</i>
<i>Cola drink.....</i>	<i>Liquid detergent</i>	<i>Urine.....</i>	<i>Liquid detergent, Water</i>
<i>Crème de Menthe (green) Liquid detergent</i>		<i>Vomit.....</i>	<i>Warm detergent, Water, White vinegar</i>
		<i>Wine .....</i>	<i>Liquid detergent, Ammonia 3-6%, Water, vinegar</i>

## HOT ROD/HOT SPOTTER WARRANTY

The spotter is warranted to be free from defects in material and workmanship. The warranty is limited as follows:

<b>Component</b>	<b>Term of Warranty</b>
Rotational molded parts	3 years
Pump	1 year
Vacuum motor	1 year
Heating element	1 year

The warranty does not apply to certain consumable or wear parts such as:

Motor carbon brushes	Bearings
Hoses & hose fittings	Filters & gaskets

The warranty does not apply to damage or failure caused by abuse, misuse, neglect, disassembly, alteration, unauthorized modification or repair, lack of proper maintenance, theft or damage by freight carriers. The warranty applies to parts, labor, and ground freight only.

In order to obtain parts warranty, the following procedures must be followed:

1. Customer must call the Distributor for an RGA (Return Goods Authorization) Number.
2. The defective part must be returned via ground freight prepaid to the Distributor with an RGA number accompanied by a copy of the original purchase invoice. We are not responsible for the cost of packaging inbound freight, nor inbound freight damage. Pack machine carefully.
3. Only the Distributor or its authorized dealers may make warranty repairs on Hot Rod/Hot Spotter products. Others do so at their own risk and expense.

This warranty limits the Distributor's liability for defects in workmanship or materials to replacement of defective parts only. The Distributor will not be liable for incidental or consequential damages arising from the use of any of its products, whether defective or not.

The need for proper maintenance and care for this product cannot be overstated. Poor maintenance, neglect or abuse can prove to be very expensive. Never leave your machine in a truck or other outside storage area where there is a potential for freezing.

1. Pumps carry a 1 year warranty. However coverage may be denied if there is evidence of the use of chemicals in the solution tank, fiber/hair build-up in the pump chamber, or water damage to the electrical portion of the pump.
2. Vacuum motors carry a 1 year warranty. Motors showing any of the following signs of abuse will be excluded from coverage:
  - a. Signs of moisture in or on the fan/motor chamber area. (This means that if water or foam has been sucked through the motor the warranty is voided.)
  - b. Dirty motors, where failure has been caused by inadequate filtrating.
  - c. Motors where excessive wear indicates that the motor has been used to the full extent of it's normal life expectancy, regardless of the date code stamp.

Your have purchased a quality product. Each of its components has been tested and approved for use. It is unlikely that you will ever have a warranty claim if you properly maintain this machine.

**This warranty is non-transferable.**



201 COMMERCE DRIVE • MONTGOMERYVILLE, PA 18936

215-393-4700 • 800-331-1423 • FAX 215-393-4800